

CLASSIC STEEL

18-0 X 15-0 X 36-6 CAPE MAY LEFT



PART#: ISK-NO-1836-00-STD

SURFACE AREA: (ft²): 529

PERIMETER: 92'-6"

DATE: 01/01/07

LINER AREA (ft²): 657

VOLUME (US Gal): 17,365

SCALE: 1/8" = 1'-0"

SFTY COVER AREA (ft²): 830

VOLUME (Litres): 65,733



DIVING/SLIDING EQUIPMENT SHALL BE DESIGNED FOR SWIMMING POOLS AND SHALL BE INSTALLED IN ACCORDANCE WITH THE DIVING/SLIDING EQUIPMENT MANUFACTURER'S SPECIFICATIONS. PLEASE CONTACT THE DIVING/SLIDING EQUIPMENT MANUFACTURER FOR THEIR SPECIFICATIONS.

MEETS DEPTH AND SHAPE MINIMUM STANDARD ANS/SP15-2003

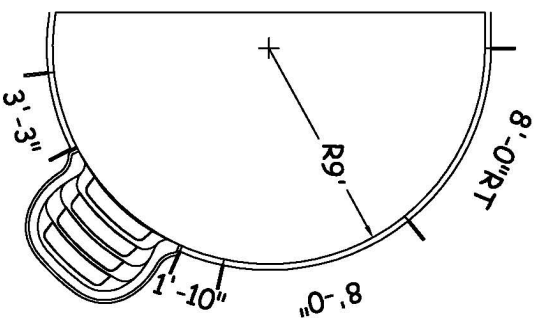

6 STEP

8 STEP

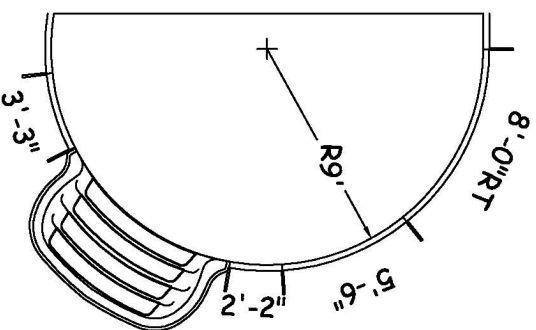

DWG#: CLN000S1836L07

SHEET: 1 OF 2

CAPE MAY

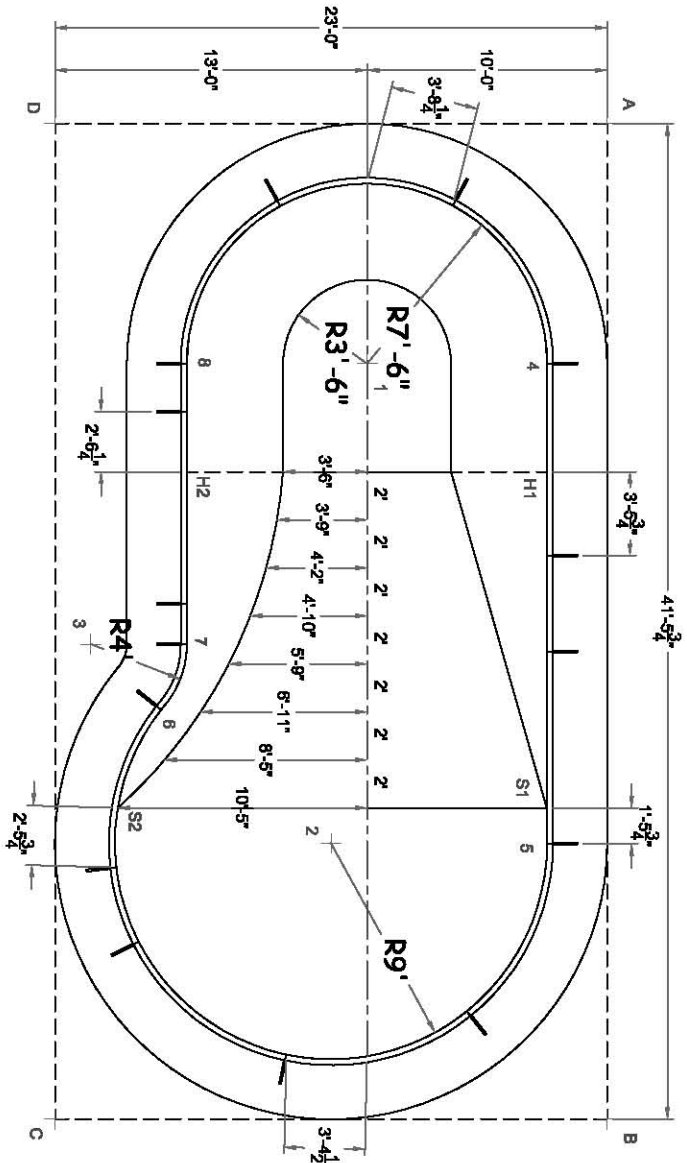

	A	B	C	D
1	14'-1 3/4"	33'-0 1/4"	34'-0 1/2"	16'-4 3/4"
2	32'-1 1/4"	16'-3 1/4"	16'-3 1/4"	32'-1 1/4"
3	30'-6 1/2"	29'-2 3/4"	19'-10 1/4"	21'-8 3/4"
4	10'-3 1/2"	31'-7"	37'-6 3/4"	22'-9 3/4"
5	30'-1"	11'-9"	23'-6"	36'-4"
6	30'-8"	25'-2 3/4"	17'-7 1/2"	24'-9 3/4"
7	27'-10 1/4"	26'-5"	20'-6 1/2"	22'-4 1/2"
8	20'-1 3/4"	36'-0 1/4"	31'-11 1/2"	11'-4 3/4"
S1	28'-7 1/4"	13'-2 1/2"	24'-3"	35'-1 1/4"
S2	35'-0 1/2"	24'-1 3/4"	13'-2 3/4"	28'-7 1/2"
H1	14'-8 1/2"	27'-1"	33'-10 1/2"	25'-1 1/4"
H2	22'-8 3/4"	32'-1 3/4"	27'-6 1/4"	15'-6"
A	-	41'-5 3/4"	47'-5"	23'-0"

DIAGONALS	1 TO 2	20'-0 1/4"
1 TO 2	20'-0 1/4"	
1 TO 3	16'-4 3/4"	
1 TO 4	7'-6"	
1 TO 5	21'-4 1/4"	
1 TO 6	16'-9 1/4"	
1 TO 7	13'-10 1/2"	
1 TO 8	7'-6"	
1 TO S1	19'-11 1/2"	
1 TO S2	21'-2 1/2"	
1 TO H1	8'-9"	
1 TO H2	8'-9"	
2 TO 3	13'-0"	
2 TO 4	21'-11"	
2 TO 5	9'-0"	
2 TO 6	9'-0"	
2 TO 7	10'-2 3/4"	
2 TO 8	20'-10 1/4"	
2 TO S1	9'-1 1/2"	
2 TO S2	9'-0"	
2 TO H1	17'-10 3/4"	
2 TO H2	16'-7"	
3 TO 4	22'-3 3/4"	
3 TO 5	20'-8 3/4"	
3 TO 6	4'-0"	
3 TO 7	4'-0"	
3 TO 8	12'-4 1/4"	
3 TO S1	20'-2 1/4"	
3 TO S2	6'-11"	
3 TO H1	20'-3 3/4"	
3 TO H2	8'-2 3/4"	
4 TO 5	20'-0"	
4 TO 6	21'-7 1/4"	
4 TO 7	19'-0 1/4"	
4 TO 8	15'-0"	
4 TO S1	18'-6 1/4"	
4 TO S2	25'-8 3/4"	
4 TO H1	4'-6 1/4"	
4 TO H2	15'-8"	
5 TO 6	17'-0 1/4"	
5 TO 7	17'-1 3/4"	
5 TO 8	25'-0"	
5 TO S1	1'-5 3/4"	
5 TO S2	17'-11 1/4"	
5 TO H1	15'-5 3/4"	
5 TO H2	21'-6 3/4"	

BILL OF MATERIALS	NO	STEP
8'-0" STRAIGHT - HS10850M	1	1
8'-0" STRAIGHT - PLAIN	2	2
4'-0" STRAIGHT - PLAIN	1	1
2'-0" STRAIGHT - PLAIN	1	1
1'-8" STRAIGHT - PLAIN	1	1
8'-0" X 9'-0" RADIUS - PLAIN	2	1
8'-0" X 9'-0" RADIUS - HR	1	1
7'-0" X 9'-0" RADIUS - PLAIN	1	1
5'-6" X 9'-0" RADIUS - PLAIN	-	-
3'-3" X 9'-0" RADIUS - PLAIN	1	1
2'-2" X 9'-0" RADIUS - PLAIN	-	-
1'-10" X 9'-0" RADIUS - PLAIN	-	-
8'-0" X 7'-6" RADIUS - PLAIN	1	1
8'-0" X 7'-6" RADIUS - HR	1	1
7'-6" X 7'-6" RADIUS - PLAIN	1	1
3'-0" X 4'-0" REV RAD - PLAIN	1	1
A-FRAME	15	17
HARDWARE STRAIGHT 160 PACK	2	2
REBAR, STAKE 18 in. (25 PACK)	2	2
OPTIONAL DECK SUPPORT	35	34

DIAGONALS	6 TO 7	2'-11 1/4"
6 TO 7	2'-11 1/4"	
6 TO 8	14'-5 1/2"	
6 TO S1	16'-7"	
6 TO S2	4'-5 3/4"	
6 TO H1	18'-10 1/2"	
6 TO H2	9'-11 1/2"	
7 TO 8	11'-8 1/4"	
7 TO S1	16'-5 3/4"	
7 TO S2	7'-4 3/4"	
7 TO H1	16'-7 1/2"	
7 TO H2	7'-2 1/4"	
8 TO S1	23'-10"	
8 TO S2	18'-8 3/4"	
8 TO H1	15'-8"	
8 TO H2	4'-6 1/4"	
S1 TO S2	17'-10 1/2"	
S1 TO H1	14'-0"	
S1 TO H2	20'-6 1/4"	
S2 TO H1	22'-8 1/2"	
S2 TO H2	14'-3 1/2"	
H1 TO H2	15'-0"	