

6' STEP

8' STEP

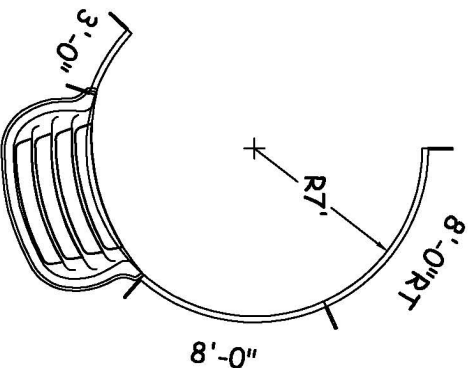

CLASSIC STEEL
14-0 X 11-0 X 28-4 CAPE MAY LEFT

PART#: ISK-NO-1428-00-STD	SURFACE AREA: (ft ²): 311	PERIMETER: 71'-9"
DATE: 01/01/07	LINER AREA (ft ²): 397	VOLUME (US Gal): 8,660
SCALE: 1/8" = 1'-0"	SFTY COVER AREA (ft ²): 533	VOLUME (Litres): 32,792



NON-DIVING POOL
USE OF DIVING EQUIPMENT
IS PROHIBITED

MEETS DEPTH AND SHAPE MINIMUM STANDARD ANS/SP15-2003

CAPE MAY

DWG#: CLN000S1428L07

SHEET: 1 OF 2

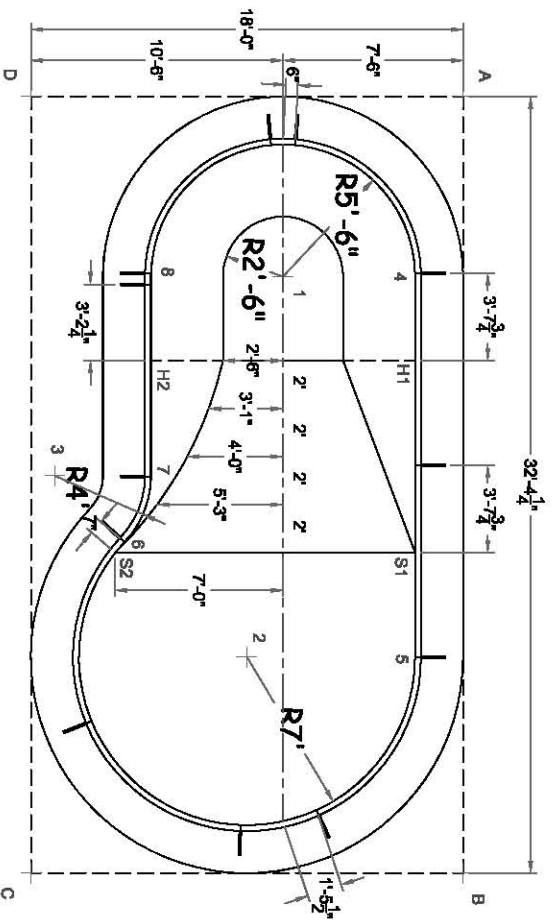

	A	B	C	D
1	10'-7 1/4"	25'-11 1/2"	26'-11 3/4"	12'-10 3/4"
2	25'-0 1/4"	12'-8 3/4"	12'-8 3/4"	25'-0 1/4"
3	23'-2 1/2"	23'-8 3/4"	16'-7"	15'-10"
4	7'-7 1/2"	25'-0 3/4"	29'-8"	17'-7 1/4"
5	23'-5 1/4"	9'-2 1/2"	18'-4 1/4"	28'-3 3/4"
6	23'-3 3/4"	19'-8 3/4"	14'-4"	18'-11 1/2"
7	20'-5 3/4"	21'-0 1/4"	17'-3 1/4"	16'-7"
8	14'-11 1/4"	28'-2"	25'-5 3/4"	8'-10 3/4"
S1	19'-1 1/4"	13'-6"	20'-10"	24'-10"
S2	23'-10 3/4"	19'-8 1/2"	13'-9 1/2"	19'-3 3/4"
H1	11'-2 1/4"	21'-5 1/4"	26'-8 1/4"	19'-5"
H2	17'-0 1/4"	25'-0"	21'-11"	12'-1"
A	-	32'-4 1/4"	37'-0 1/4"	18'-0"

DIAGONALS		
1 TO 2	15'-11"	
1 TO 3	12'-7 1/4"	
1 TO 4	5'-6"	
1 TO 5	16'-9 1/2"	
1 TO 6	12'-10 1/2"	
1 TO 7	9'-11 3/4"	
1 TO 8	5'-6"	
1 TO S1	12'-9"	
1 TO S2	13'-5 1/2"	
1 TO H1	8'-6 1/4"	
1 TO H2	6'-6 1/4"	
2 TO 3	10'-12"	
2 TO 4	17'-5 1/2"	
2 TO 5	7'-0"	
2 TO 6	7'-0"	
2 TO 7	8'-6 1/4"	
2 TO 8	16'-5 3/4"	
2 TO S1	8'-3"	
2 TO S2	7'-0"	
2 TO H1	14'-2 1/4"	
2 TO H2	12'-11 3/4"	
3 TO 4	17'-2 1/2"	
3 TO 5	16'-9 1/2"	
3 TO 6	4'-0"	
3 TO 7	4'-0"	
3 TO 8	9'-4"	
3 TO S1	15'-4"	
3 TO S2	4'-0 3/4"	
3 TO H1	15'-9"	
3 TO H2	6'-3"	
4 TO 5	16'-0"	
4 TO 6	16'-6"	
4 TO 7	13'-10 1/2"	
4 TO 8	11'-0"	
4 TO S1	11'-7 3/4"	
4 TO S2	17'-0 3/4"	
4 TO H1	3'-7 3/4"	
4 TO H2	11'-7"	
5 TO 6	13'-0 1/4"	
5 TO 7	13'-4"	
5 TO 8	19'-5"	
5 TO S1	4'-4 1/4"	
5 TO S2	13'-2 3/4"	
5 TO H1	12'-4 1/4"	
5 TO H2	16'-6 1/2"	
6 TO 7	2'-11 1/2"	
6 TO 8	11'-3"	
6 TO S1	12'-1 1/2"	
6 TO S2	0'-7"	

DESCRIPTION	NO	6'	8'
8"Ø STRAIGHT - HS10850M	1	1	1
8"Ø STRAIGHT - PLAIN	2	2	2
0"Ø STRAIGHT - PLAIN	1	1	1
8"Ø X 7'0" RADIUS - PLAIN	2	1	1
8"Ø X 7'0" RADIUS - HR	1	1	1
3"Ø X 7'0" RADIUS - PLAIN	1	1	1
3"Ø X 7'0" RADIUS - PLAIN	-	-	1
1"-10" X 7'-0" RADIUS - PLAIN	-	1	-
8"Ø X 5'-6" RADIUS - PLAIN	1	1	1
8"Ø X 5'-6" RADIUS - HR	1	1	1
1"Ø X 5'-6" RADIUS - PLAIN	1	1	1
3"Ø X 4'-0" REV RAD - PLAIN	1	1	1
A-FRAME	12	13	12
HARDWARE STRAIGHT 150 PACK	2	2	2
REBAR, STAKE 18 IN. (25 PACK)	1	1	1
OPTIONAL DECK SUPPORT	28	27	26

DIAGONALS	
6 TO H1	14'-3 1/4"
6 TO H2	7'-7 3/4"
7 TO 8	8'-5 1/2"
7 TO S1	11'-5 1/4"
7 TO S2	3'-6 1/4"
7 TO H1	12'-0"
7 TO H2	4'-9 3/4"
8 TO S1	16'-0 1/4"
8 TO S2	11'-8 3/4"
8 TO H1	11'-7"
8 TO H2	3'-7 3/4"
S1 TO S2	12'-5 3/4"
S1 TO H1	8'-0"
S1 TO H2	13'-7 1/4"
S2 TO H1	14'-10"
S2 TO H2	8'-1 3/4"
H1 TO H2	11'-0"

14-0 X 11-0 X 28-4 CAPE MAY LEFT

DWG #: CLNO0051428L07

DATE: 01/01/07

SHEET: 2 OF 2