

CLASSIC STEEL
18-0 X 21-3 X 38-0 GEMINI RIGHT

PART#: ISK-GM-1838-00-STD
 DATE: 01/01/07
 SCALE: 1/8" = 1'-0"

SURFACE AREA: (ft²): 615
 PERIMETER: 99'-3"
 LINER AREA (ft²): 684
 VOLUME (US Gal): 20,189
 SFTY COVER AREA (ft²): 994
 VOLUME (Litres): 76,423



MEETS DEPTH AND SHAPE MINIMUM STANDARD ANS/INSP15-2003

DIVING/SLIDING EQUIPMENT SHALL BE DESIGNED FOR SWIMMING POOLS AND SHALL BE INSTALLED IN ACCORDANCE WITH THE DIVING/SLIDING EQUIPMENT MANUFACTURER'S SPECIFICATIONS. PLEASE CONTACT THE DIVING/SLIDING EQUIPMENT MANUFACTURER FOR THEIR SPECIFICATIONS.



6' STEP

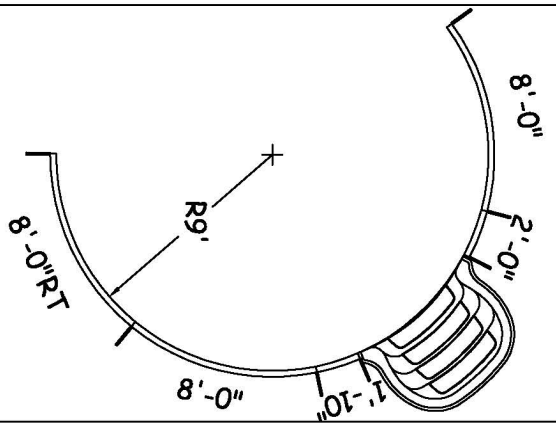

8' STEP

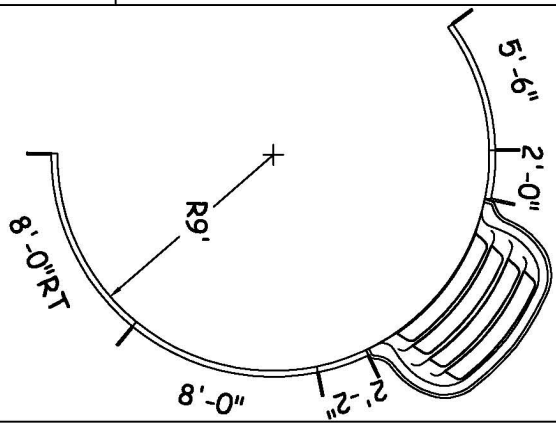

DWG#: CLGM00S1838R07

