

6' STEP

8' STEP



CLASSIC STEEL
16-0 X 17-7 X 29-11 CRESCENT RIGHT

PART#: ISK-CR-1630-00-STD	SURFACE AREA: (ft ²): 431	PERIMETER: 79'-0"
DATE: 01/01/07	LINER AREA (ft ²): 479	VOLUME (US Gal): 12,002
SCALE: 1/8" = 1'-0"	SFTY COVER AREA (ft ²): 678	VOLUME (Litres): 45,432



NON-DIVING POOL
USE OF DIVING EQUIPMENT
IS PROHIBITED

MEETS DEPTH AND SHAPE MINIMUM STANDARD ANS/SP15-2003

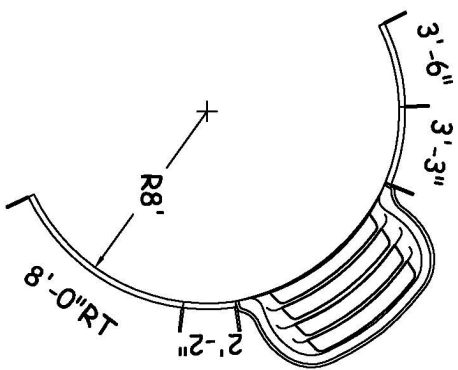

DWG#: CLCR00S1630R07

CRESCENT

SHEET: 1 OF 2

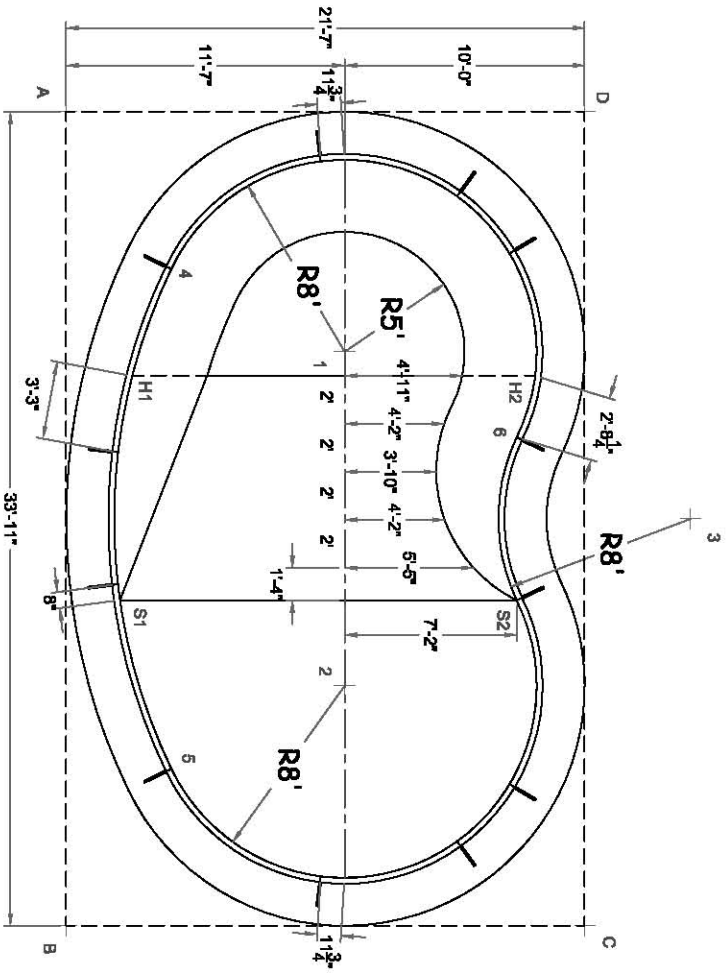

	A	B	C	D
1	15'-3 3/4"	26'-6 3/4"	25'-1 1/4"	14'-1 3/4"
2	26'-6 3/4"	15'-3 3/4"	14'-1 3/4"	25'-1 1/4"
3	31'-0 1/2"	31'-0 1/2"	17'-6 1/4"	17'-6 1/4"
4	27'-8 1/2"	27'-8 1/2"	32'-4"	18'-5"
5	27'-8 1/2"	7'-10 1/2"	18'-5"	32'-4"
6	23'-1 3/4"	27'-9"	20'-6 1/2"	13'-10 1/4"
S1	20'-5 1/2"	13'-9"	23'-7 1/2"	28'-1"
S2	27'-8"	23'-1 3/4"	13'-10 1/4"	20'-6 1/2"
H1	11'-4"	23'-0 3/4"	29'-8"	21'-9 3/4"
H2	22'-5"	30'-1 1/4"	23'-0"	11'-2 1/4"
A	-	33'-1 1/4"	40'-2 1/4"	21'-7"

DIAGONALS	
1 TO 2	13'-11"
1 TO 3	16'-0"
1 TO 4	8'-0"
1 TO 5	18'-9 3/4"
1 TO 6	8'-0"
1 TO S1	13'-11 1/4"
1 TO S2	12'-7"
1 TO H1	8'-10 3/4"
1 TO H2	8'-0"
2 TO 3	16'-0"
2 TO 4	18'-9 3/4"
2 TO 5	8'-0"
2 TO 6	12'-7"
2 TO S1	10'-0"
2 TO S2	8'-0"
2 TO H1	15'-7 3/4"
2 TO H2	15'-1 3/4"
3 TO 4	24'-0"
3 TO 5	24'-0"
3 TO 6	8'-0"
3 TO S1	24'-0"
3 TO S2	8'-0"
3 TO H1	24'-0"

DIAGONALS	
3 TO H2	8'-9 1/2"
4 TO 5	20'-10"
4 TO 6	16'-0"
4 TO S1	13'-11 1/2"
4 TO S2	19'-11 1/4"
4 TO H1	4'-9"
4 TO H2	15'-9 1/2"
5 TO 6	19'-11 1/4"
5 TO S1	7'-4"
5 TO S2	16'-0"
5 TO H1	16'-5 1/4"
5 TO H2	22'-3 3/4"
6 TO S1	17'-10 1/4"
6 TO S2	6'-9 1/4"
6 TO H1	16'-2 1/2"
6 TO H2	2'-8 1/4"
S1 TO S2	16'-6 1/4"
S1 TO H1	9'-4 1/4"
S1 TO H2	19'-7 3/4"
S2 TO H1	18'-6 1/4"
S2 TO H2	9'-4 1/2"
H1 TO H2	16'-9 1/4"

DESCRIPTION	NO	STEP
8'-0" X 24'-0" RADIUS - HSYOBSON	1	1
8'-0" X 24'-0" RADIUS - PLAIN	1	1
5'-6" X 24'-0" RADIUS - PLAIN	1	1
8'-0" X 8'-0" RADIUS - PLAIN	2	1
8'-0" X 8'-0" RADIUS - HR	2	2
8'-0" X 8'-0" RADIUS - PLAIN	2	2
3'-6" X 8'-0" RADIUS - PLAIN	-	1
3'-3" X 8'-0" RADIUS - PLAIN	2	2
2'-2" X 8'-0" RADIUS - PLAIN	-	1
1'-10" X 8'-0" RADIUS - PLAIN	-	1
7'-0" X 8'-0" REV RAD - PLAIN	1	1
A-FRAME	12	13
HARDWARE STRAIGHT 160 PACK	1	1
REBAR STAKE 18 IN. (25 PACK)	1	1
OPTIONAL DECK SUPPORT	29	29