

CLASSIC STEEL

22-0 X 16-0 X 34-0 CONTEMPORARY FULL-L LEFT



PART#: ISK-CL-2234-24-STD

SURFACE AREA: (ft<sup>2</sup>): 592

PERIMETER: 102'-11"

DATE: 01/01/07

LINER AREA (ft<sup>2</sup>): 628

VOLUME (US Gal): 16,485

SCALE: 1/8" = 1'-0"

SFTY COVER AREA (ft<sup>2</sup>): 744

VOLUME (Litres): 62,402



NON-DIVING POOL  
USE OF DIVING EQUIPMENT  
IS PROHIBITED

MEETS DEPTH AND SHAPE MINIMUM STANDARD ANS/SP15-2003

6' STEP

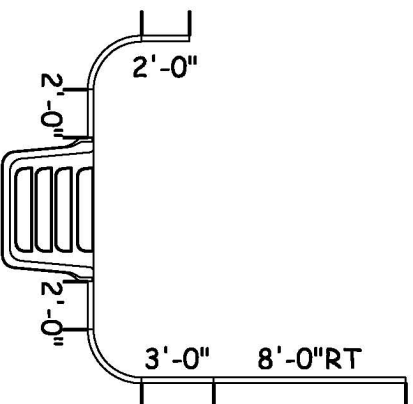

8' STEP

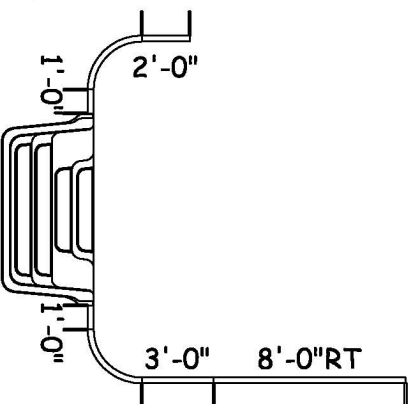

DWG#: CLCL24S2234L07

SHEET: 1 OF 2

CONTEMPORARY FULL-L

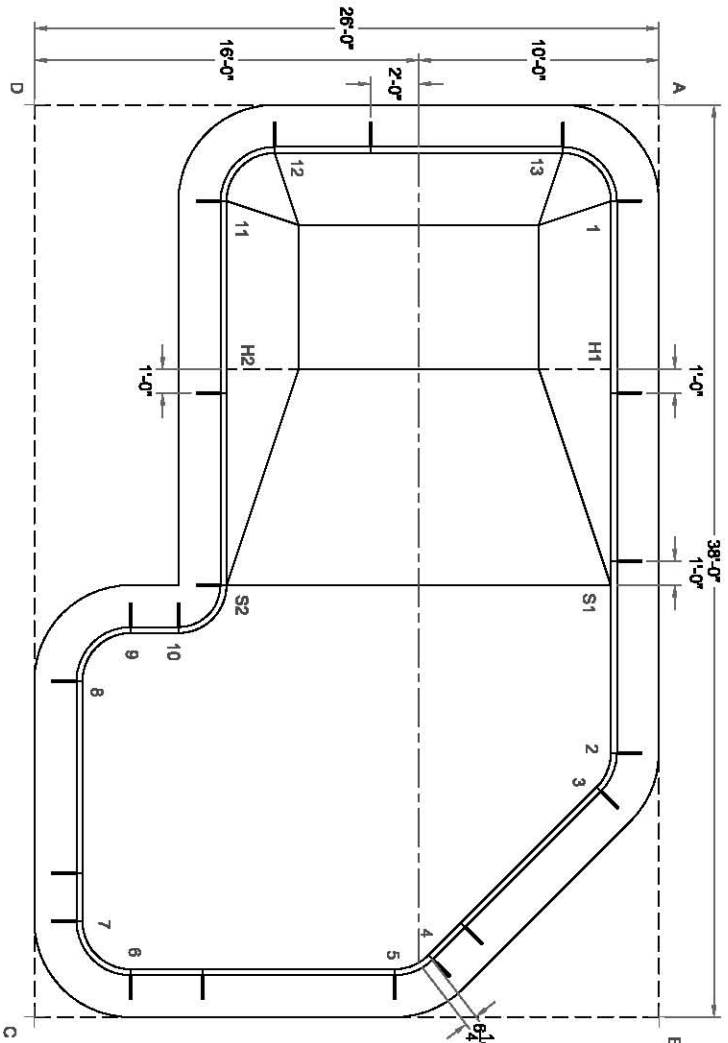

	A	B	C	D
1	4'-5 3/4"	34'-0 3/4"	41'-7 1/2"	24'-4"
2	27'-1"	11'-2 1/4"	26'-4 3/4"	36'-1 1/2"
3	28'-6 1/2"	9'-11 1/4"	25'-3 1/2"	36'-9 3/4"
4	36'-8 1/4"	9'-11 1/4"	16'-7 1/2"	39'-0 1/2"
5	37'-7 3/4"	11'-2 1/4"	15'-1 1/2"	39'-0"
6	42'-2 1/4"	22'-1"	4'-5 3/4"	36'-2 3/4"
7	41'-7 1/2"	24'-4"	4'-5 3/4"	34'-0 3/4"
8	33'-11 1/4"	27'-9 1/2"	14'-1 3/4"	24'-1"
9	31'-1 1/4"	27'-2 1/2"	16'-6"	22'-4 1/4"
10	29'-8 3/4"	25'-7 1/4"	17'-1"	22'-9 3/4"
11	18'-5 1/4"	38'-5 3/4"	34'-11 1/4"	8'-11 1/4"
12	16'-1 1/2"	39'-4 3/4"	37'-4 1/4"	10'-2 1/2"
13	4'-5 3/4"	36'-2 3/4"	42'-2 1/4"	22'-1"
S1	20'-1 1/4"	18'-1 1/4"	30'-0"	31'-3"
S2	26'-1 1"	25'-5 1/2"	19'-8 1/4"	21'-6 1/2"
H1	11'-2 1/4"	27'-1"	36'-1 1/2"	26'-4 3/4"
H2	21'-1 1/4"	32'-5 1/2"	28'-2"	13'-7 1/4"
A	-	36'-0"	46'-0 1/2"	26'-0"

DIAGONALS		
1 TO 2	23'-0"	
1 TO 3	24'-5"	
1 TO 4	32'-3 3/4"	
1 TO 5	33'-3"	
1 TO 6	37'-8 3/4"	
1 TO 7	37'-2 1/2"	
1 TO 8	29'-8 3/4"	
1 TO 9	26'-1 1"	
1 TO S1	16'-0"	
1 TO S2	22'-7 1/2"	
1 TO H1	7'-0"	
1 TO H2	17'-5 1/2"	
2 TO 3	1'-6 1/4"	
2 TO 4	11'-4"	
2 TO 5	12'-8 3/4"	
2 TO 6	21'-11 1/4"	
2 TO 7	23'-1"	
2 TO 8	22'-2 1/2"	
2 TO 9	20'-7 1/2"	
2 TO S1	7'-0"	
2 TO S2	17'-5 1/2"	
2 TO H1	16'-0"	
2 TO H2	22'-7 1/2"	
6 TO 7	2'-10"	
6 TO 9	14'-0"	
6 TO 11	32'-3"	
6 TO 13	38'-5 3/4"	
6 TO S1	25'-7 1/4"	
6 TO S2	16'-6"	
6 TO H1	32'-0 1/4"	
6 TO H2	25'-3 3/4"	
7 TO 9	12'-2"	
7 TO 11	30'-7 1/4"	
7 TO 13	37'-8 3/4"	
7 TO S1	26'-1"	
7 TO S2	15'-2 3/4"	
7 TO H1	31'-10"	
7 TO H2	23'-9 1/4"	
8 TO 10	4'-5 3/4"	
8 TO 12	23'-5"	
8 TO S1	22'-4 1/4"	
8 TO S2	7'-2 1/2"	
8 TO H1	25'-6 3/4"	
8 TO H2	14'-3 3/4"	
9 TO 12	20'-10 1/2"	
9 TO S1	20'-1 1/4"	
9 TO S2	4'-5 3/4"	
9 TO H1	22'-10"	
9 TO H2	11'-8 1/2"	

DESCRIPTION	NO	6'	8'
8" STRAIGHT - HS10850M	1	1	1
8" STRAIGHT - PLAIN	5	4	4
8" STRAIGHT - HR	2	2	2
7" STRAIGHT - PLAIN	1	1	1
4" STRAIGHT - PLAIN	1	1	1
3" STRAIGHT - PLAIN	1	1	1
2" STRAIGHT - PLAIN	2	3	1
1'-1" STRAIGHT - PLAIN	1	1	1
1'-0" STRAIGHT - PLAIN	-	-	2
3/2" X 2" RADIUS 90° CORNER	4	4	4
1-7/8" X 2" RADIUS 45° CORNER	2	2	2
3/2" X 2" REV/RAD 90° CORNER	1	1	1
A-FRAME	21	22	22
HARDWARE STRAIGHT 150 PACK	2	2	2
REBAR, STAKE 18 IN. (25 PACK)	2	2	2
OPTIONAL DECK SUPPORT	40	39	39

DIAGONALS	
10 TO 11	18'-1 1/4"
10 TO 12	20'-4 3/4"
10 TO 13	25'-7 1/4"
10 TO S1	18'-1 1/4"
10 TO S2	2'-10"
10 TO H1	21'-1 1/4"
10 TO H2	11'-2 1/4"
S1 TO S2	16'-0"
S1 TO H1	9'-0"
S1 TO H2	18'-4 1/4"
S2 TO H1	18'-4 1/4"
S2 TO H2	9'-0"
H1 TO H2	18'-0"